

# GMA 245

## pilot's guide





Copyright © 2016-2019, 2023 Garmin Ltd. or its subsidiaries. All rights reserved.

This manual reflects the operation of GMA 245 units with mod level 0 or later. Some differences in operation may be observed when comparing the information in this manual to earlier or later Mod status levels.

Garmin International, Inc., 1200 East 151st Street, Olathe, Kansas 66062, U.S.A.

Garmin AT, Inc., 2345 Turner Road SE, Salem, OR 97302, U.S.A.

Garmin (Europe) Ltd., Liberty House, Hounsdown Business Park, Southampton, Hampshire SO40 9LR U.K.

Garmin Würzburg GmbH, Beethovenstrasse 1a, 97080 Würzburg, Germany

Garmin Corporation, No. 68, Zhangshu 2nd Road, Xizhi District, New Taipei City, Taiwan

Web Site Address: **[www.garmin.com](http://www.garmin.com)**

Except as expressly provided herein, no part of this manual may be reproduced, copied, transmitted, disseminated, downloaded or stored in any storage medium, for any purpose without the express written permission of Garmin. Garmin hereby grants permission to download a single copy of this manual and of any revision to this manual onto a hard drive or other electronic storage medium to be viewed for personal use, provided that such electronic or printed copy of this manual or revision must contain the complete text of this copyright notice and provided further that any unauthorized commercial distribution of this manual or any revision hereto is strictly prohibited.

Garmin® is a registered trademark of Garmin Ltd. or its subsidiaries. These trademarks may not be used without the express permission of Garmin.

©2019 The Bluetooth® word mark and logos are registered trademarks owned by Bluetooth SIG, Inc. and any use of such marks by Garmin is under license. Other trademarks and trade names are those of their respective owners.





---

**CAUTION:** *Incorrect aircraft wiring could short the left channel or both channels to ground if a monaural headset is plugged into the stereo jacks. If wired incorrectly, fail-safe operation will not work.*

---

## AVIATION LIMITED WARRANTY

For warranty information, visit <http://www.garmin.com/en-US/legal/aviation-limited-warranty>.

## FCC

011-03519-00 contains FCC ID: QOQWT32I

011-03519-01 contains FCC ID: 2ADHKBM83SM1

## NOTE

This device complies with part 15 of the FCC Rules. Operation is subject to the following two conditions: (1) This device may not cause harmful interference, and (2) this device must accept any interference received, including interference that may cause undesired operation.

This equipment has been tested and found to comply with the limits for a Class B digital device, pursuant to part 15 of the FCC Rules. These limits are designed to provide reasonable protection against harmful interference in a residential installation. This equipment generates, uses and can radiate radio frequency energy, and if not installed and used in accordance with the instructions, may cause harmful interference to radio communications. However, there is no guarantee that interference will not occur in a particular installation. If this equipment does cause harmful interference to radio or television reception, which can be determined by turning the equipment off and on, the user is encouraged to try to correct the interference by one or more of the following measures:

- Reorient or relocate the receiving antenna
- Increase the separation between the equipment and receiver
- Connect the equipment into an outlet on a circuit different from that to which the receiver is connected
- Consult the dealer or an experienced radio/TV technician for help

## **FCC RF Radiation Exposure Statement:**

This equipment complies with FCC radiation exposure limits set forth for an uncontrolled environment. This equipment should be installed and operated with minimum distance 20mm between the radiator and your body. This transmitter must not be co-located or operating in conjunction with any other antenna or transmitter.

## **IC**

011-03519-00 contains IC: 5123A-BGTWT32I

011-03519-01 contains IC: 20266-BM83SM1

## **NOTE**

This device complies with Innovation, Science and Economic Development Canada license-exempt RSS standard(s). Operation is subject to the following two conditions: (1) this device may not cause interference, and (2) this device must accept any interference, including interference that may cause undesired operation of the device.

Cet appareil est conforme aux normes RSS sans licence du ministère Innovation, Sciences et Développement économique Canada. Son fonctionnement est soumis aux deux conditions suivantes : (1) ce périphérique ne doit pas causer d'interférences et (2) doit accepter toute interférence, y compris les interférences pouvant entraîner un fonctionnement indésirable de l'appareil.

## **Anatel Warning**

Este equipamento não tem direito a proteção contra interferência prejudicial e não pode causar interferência em sistemas devidamente autorizados.

## **Declaration of Conformity**

Hereby, Garmin declares that this product is in compliance with the Directive 2014/53/EU. The full text of the EU declaration of conformity is available at the following internet address: [www.garmin.com/compliance](http://www.garmin.com/compliance).

## **UK Declaration of Conformity**

Hereby, Garmin declares that this product is in compliance with the relevant statutory requirements. The full text of the declaration of conformity is available at the following internet address: [www.garmin.com/compliance](http://www.garmin.com/compliance)

## **Radio frequency/protocol:**

2.4 GHz @ 2.42 dBm nominal

## **SOFTWARE LICENSE AGREEMENT**

BY USING THE DEVICE, COMPONENT OR SYSTEM MANUFACTURED OR SOLD BY GARMIN ("THE GARMIN PRODUCT"), YOU AGREE TO BE BOUND BY THE TERMS AND CONDITIONS OF THE FOLLOWING SOFTWARE LICENSE AGREEMENT. PLEASE READ THIS AGREEMENT CAREFULLY. Garmin Ltd. and its subsidiaries ("Garmin") grants you a limited license to use the software embedded in the Garmin Product (the "Software") in binary executable form in the normal operation of the Garmin Product. Title, ownership rights, and intellectual property rights in and to the Software remain with Garmin and/or its third-party providers. You acknowledge that the Software is the property of Garmin and/or its third-party providers and is protected under the United States of America copyright laws and international copyright treaties. You further acknowledge that the structure, organization, and code of the Software are valuable trade secrets of Garmin and/or its third-party providers and that the Software in source code form remains a valuable trade secret of Garmin and/or its third-party providers. You agree not to reproduce, decompile, disassemble, modify, reverse assemble, reverse engineer, or reduce to human readable form the Software or any part thereof or create any derivative works based on the Software. You agree not to export or re-export the Software to any country in violation of the export control laws of the United States of America.

- Features and Operation..... 9**
  - Power-UP ..... 10
  - Mono/Stereo Headsets ..... 10
  - Left/Right Knobs..... 10
- Transceivers ..... 12**
  - Split-COM Mode ..... 12
  - Transmit Indications ..... 12
  - Enabling/Disabling Monitored COM Muting ..... 14
- Receivers ..... 14**
- Intercom System (ICS) ..... 14**
  - PILOT ICS Isolation ..... 15
  - CREW ICS Isolation ..... 15
  - Adjusting Intercom Volume ..... 15
  - Adjusting Music Volume..... 15
  - Radio Mute ICS ..... 15
  - Speaker ..... 16
- 3D Audio ..... 16**
  - Enabling 3D Audio..... 16
- Clearance Recorder and Player ..... 19**
- Entertainment Inputs ..... 20**
  - Music Effects ..... 20
- Bluetooth® ..... 22**
  - Pairing a Bluetooth Device ..... 23
  - Pairing to a Garmin VIRB X or VIRB XE Action Camera..... 24
  - Pairing To A Third-Party Camera..... 24
  - Disabling Bluetooth..... 25
  - Bluetooth Media Controls ..... 25
  - Bluetooth Telephone Volume Controls..... 25
- Entertainment Muting ..... 26**
  - Radio Mute ..... 26
  - ICS Mute ..... 26
- USB Power Jack ..... 26**
- Fail-Safe Operation..... 27**

Blank Page



# FEATURES AND OPERATION



**NOTE:** The GMA 245 can be installed standalone, or connected into the G3X system via CAN bus. When connected into the G3X system, additional features are available that can be found in the G3X Touch Pilot’s Guide. Refer to GPN 190-01754-00 for the G3X Touch Pilots Guide.

The GMA 245 Audio Panel provides the traditional audio selector functions of microphone, receiver audio selection, intercom system (ICS), and speaker output. The GMA 245 also contains a COM clearance recorder, USB power jack, and Bluetooth® audio. In addition, configuration settings are accessed from the front panel in configuration mode. Refer to the Installation Manual for more information.

Pushbutton keys control audio selection. When a key is selected, an in-key annunciator is illuminated. Annunciator brightness is adjusted automatically by ambient light level. Key brightness is adjusted by the radio dimming bus control. Three AUX inputs are available for additional avionics or audio devices. One **AUX** Key turns on all three AUX inputs.

Upon installation, the unit may be configured in various ways depending on aircraft type and the needs of the pilot.

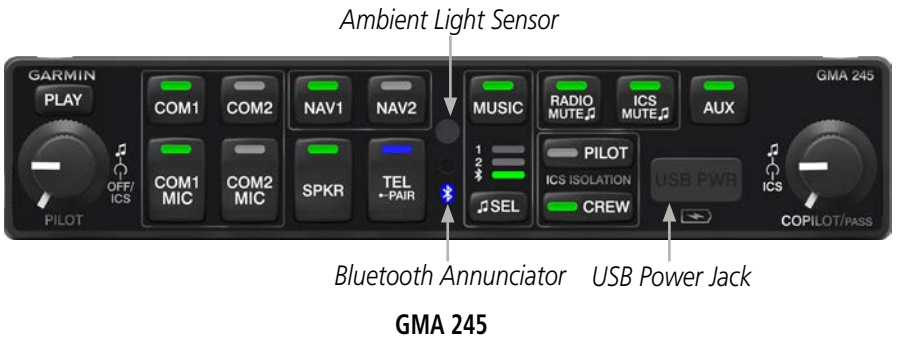

## POWER-UP

The GMA 245 performs a self-test during power-up. During the self-test all Audio Panel annunciator lights illuminate for approximately one second. Once the self-test is completed, the state of the unit is restored to the state before the unit was last turned off.

## MONO/STEREO HEADSETS

Stereo headsets are recommended when using the GMA 245. Using a monaural headset in a stereo jack shorts the right headset channel output to ground. While this does not damage the Audio Panel, a person listening on a monaural headset hears only the left channel in both ears. If a monaural headset is used at one of the passenger positions, any other passenger using a stereo headset hears audio in the left ear only.

## LEFT/RIGHT KNOBS

The **Left Inner Knob** powers-off the unit, and is used to control pilot ICS volume. The **Left Outer Knob** controls pilot music volume. The **Right Inner Knob** controls copilot and passenger ICS volume. The **Right Outer Knob** controls the copilot and passenger music volume.



Function	Action	Visual/Tactile Feedback	Aural Feedback
<b>Power OFF Audio Panel</b>	Turn <b>Left Inner Knob</b> to full counter-clockwise position	All backlight and annunciator LEDs turn off	Left Inner Knob clicks
<b>Pilot ICS Volume</b>	Turn <b>Left Inner Knob</b> right/left to increase/decrease volume	Minimum/maximum volume is reached at full counter-clockwise/clockwise position	Pilot ICS volume increases/decreases
<b>Pilot Music Volume</b>	Turn <b>Left Outer Knob</b> right/left to increase/decrease volume	Minimum/maximum volume is reached at full counter-clockwise/clockwise position	Pilot Music volume increases/decreases
<b>Copilot/ Passenger ICS Volume</b>	Turn <b>Right Inner Knob</b> right/left to increase/decrease volume	Minimum/maximum volume is reached at full counter-clockwise/clockwise position	Copilot and Passenger ICS volume increases/decreases
<b>Copilot/ Passenger Music Volume</b>	Turn <b>Right Outer Knob</b> right/left to increase/decrease volume	Minimum/maximum volume is reached at full counter-clockwise/clockwise position	Copilot and Passenger Music Volume increases/decreases

**Left/Right Knob Functions**

## TRANSCEIVERS

Audio from the #1 or #2 COM receiver can be selected independently by pressing the respective Key(s) (**COM1** or **COM2**).

Pressing **COM1 MIC** or **COM2 MIC** selects the #1 or #2 transmitter and simultaneously selects the related COM receiver (COM1 or COM2) allowing received audio to be heard. The other COM receiver can be added by pressing the respective key. When transmitting on the MIC selected COM, audio from the other COM radio is muted.

### SPLIT-COM MODE

---



**NOTE:** *Split COM performance is affected by the distance between the COM antennas and the separation of the tuned frequencies. If the selected COM frequencies are too close together, interference may be heard during transmission on the other radio.*

---

During Split-COM operation, both the pilot and the copilot can transmit simultaneously over separate radios.

Pressing both **MIC** Keys simultaneously initiates Split-COM Mode. The COM1/COM1 MIC and COM2/COM2 MIC in-key annunciators are illuminated indicating Split-COM operation. Split-COM operation is cancelled by pressing one of the selected MIC Keys again.







In Split-COM mode, the pilot uses COM1 and the copilot uses COM2

### TRANSMIT INDICATIONS

---

During COM transmission, the active transceiver (COM1 MIC or COM2 MIC) in-key Annunciator flashes approximately once per second.

During Split-COM transmission, the COM1 MIC annunciator flashes when the pilot's microphone PTT is pressed. The COM2 MIC annunciator flashes when the copilot's microphone PTT is pressed.

Function	Action	Key Annunciations	
<p><b>COM Selection:</b> Toggle between COM enabled and COM disabled (the audio from the current MIC selected COM is always enabled and cannot be disabled).</p>	<p>Press the corresponding <b>COM</b> Key.</p>	 COM Enabled	 COM Disabled
<p><b>MIC Selection:</b> Selects the COM used to transmit during Push-to-Talk (PTT).</p>	<p>Press the corresponding <b>MIC</b> Key. The last MIC pressed remains selected and deselects all others.</p>	 MIC Enabled	 MIC Disabled
<p><b>Transmit Indication:</b> Audio is sent from the corresponding Crew MIC to the selected COM. *</p>	<p>Push-to-Talk (PTT) keyed.</p>	 MIC in-key annunciator flashes.	
<p><b>Split-COM Mode:</b> The pilot transmits on COM1 and the copilot transmits on COM2 independently.</p>	<p>Simultaneously press <b>COM1 MIC</b> and <b>COM2 MIC</b> keys.</p>		

\* The pilot has priority when transmitting in the case that both crew members attempt to transmit on the same COM.

Transceiver Key Functions

## ENABLING/DISABLING MONITORED COM MUTING

Press and hold **COM1** or **COM2** to enable/disable monitored COM muting during reception of audio from the COM radio selected for transmission.

## RECEIVERS

Pressing the **NAV1** and/or **NAV2** Key(s) selects/deselects the receiver audio for the corresponding navigation radio source. The selected audio source can be heard over the headset and the speaker **SPKR** (if selected). All radios can be selected individually or simultaneously.



Selecting a NAV Radio Receiver

## INTERCOM SYSTEM (ICS)

The GMA 245 intercom system (ICS) includes two MUSIC inputs, Bluetooth source, and one wired telephone input for the pilot, copilot and passengers. The intercom provides Pilot and Crew audio isolation.



Pilot/Crew ICS Isolation



**NOTE:** The **PILOT** and **CREW ICS ISOLATION** states are exclusive. Both cannot be active at the same time. When neither Pilot or Crew are active, the unit is in All ICS mode. In this mode, the pilot, copilot, and passengers communicate with each other.

## PILOT ICS ISOLATION

Pressing the **PILOT** 'ICS ISOLATION' Key isolates the pilot from all other ICS positions (copilot and passengers). The copilot and passengers share communication between themselves but cannot communicate with the pilot. A solid annunciation of the in-key annunciator indicates PILOT ICS ISOLATION is active.

## CREW ICS ISOLATION

Pressing the **CREW** 'ICS ISOLATION' Key places the pilot and copilot on a common ICS communication channel. The passengers are on their own intercom channel and can communicate with each other, but cannot communicate with the pilot and copilot. A solid annunciation of the in-key annunciator indicates CREW ICS ISOLATION is active.

## ADJUSTING INTERCOM VOLUME

Turn the **Left Inner Knob** to adjust the Pilot ICS volume. Turn the **Right Inner Knob** to adjust the Copilot/Passenger ICS volume.

## ADJUSTING MUSIC VOLUME

Turn the **Left Outer Knob** to adjust the Pilot music volume. Turn the **Right Outer Knob** to adjust the Copilot/Passenger music volume.

## RADIO MUTE ICS

Press and hold the **RADIO MUTE**  Key to enable or disable muting of intercom audio when radio (i.e., COM, NAV, or AUX) audio is active.

## SPEAKER

---



**NOTE:** *Speaker audio turns off in circumstances where aircraft power falls below 11 volts.*

---

All of the radios can be heard over the cabin speaker. Pressing the **SPKR** Key selects and deselects the cabin speaker. Radios are muted to the speaker when a COM microphone is keyed. Aural alerts and warnings are always heard on the speaker, even when the speaker is not selected.

## 3D AUDIO

3D Audio is useful when multiple audio sources are present. By using different responses in each ear, 3D audio processing creates the illusion that each audio source is coming from a unique location or seat position.

Because this feature uses different signals for left and right channels, it requires wiring for stereo intercom and stereo headsets. If 3D audio is activated when mono headsets are in use, the listener will still hear all audio sources; however, there is no benefit from location separation.

With a single COM selected and 3D Audio enabled, the listener hears the audio source at the 12 o'clock position. If both COMs are selected, the listener hears COM1 at 11 o'clock and COM2 at the 1 o'clock position. All other intercom positions are processed to sound like their relative seat location. By default, the GMA 245 assumes the pilot sits in the left seat. Refer to the GMA 245 Installation Manual to make changes to the default configuration.

## ENABLING 3D AUDIO

---

Press and hold the **PILOT** Key to toggle 3D audio processing on and off for all headset positions. When 3D Audio is enabled, the aural message “3D audio left” is heard in the left ear followed by “3D audio right” in the right ear. If the aural messages are not heard in only the left and then the right ear respectively, the cause may be aircraft wiring or headset settings.



Refer to the following table if a headset or aircraft wiring problem is suspected.

<b>3D Audio Troubleshooting</b>		
<b>Symptom(s)</b>	<b>Cause(s)</b>	<b>Solution(s)</b>
"3D audio left" message heard in both ears. "3D audio right" message not heard	1) Mono headset in use	1) Use a stereo headset
	2) Stereo headset in use with mono/stereo switch set to 'mono'	2) Set mono/stereo switch on headset to 'stereo'
	3) Aircraft wiring has left audio wired to both left and right channels of stereo headset jack	3) If after checking solutions #1 and #2 see a service center as soon as possible to inspect/correct wiring. This wiring fault can cause fail-safe audio not to function.
"3D audio left" message heard in both ears, followed by "3D audio right" message heard in both ears	1) Mono headset in use	1) Use a stereo headset
	2) Stereo headset in use with mono/stereo switch set to mono	2) Set mono/stereo switch on headset to 'stereo'
	3) Incorrect aircraft wiring (left/right shorted together)	3) If after checking solutions #1 and #2 see a service center as soon as possible to inspect/correct wiring. This wiring fault can cause fail-safe audio not to function.
<b>Symptom(s)</b>	<b>Cause(s)</b>	<b>Solution(s)</b>
"3D audio right" message heard in both ears. "3D audio left" not heard	1) Incorrect aircraft wiring (right channel used for mono instead of left or left/right swapped)	1) See a service center as soon as possible to inspect/correct wiring. This wiring fault can cause fail-safe audio not to function.

<b>3D Audio Troubleshooting</b>		
"3D audio left" message heard in right ear only followed by "3D audio right" message heard in left ear only	<b>1)</b> Stereo headset is on backwards	<b>1)</b> Verify correct orientation from the left/right indication on each side of the headset or the position of the boom MIC (usually attached on left side). If the headset is backwards, the left/right position information will be swapped.
	<b>2)</b> Incorrect aircraft wiring (left/right channels swapped)	<b>2)</b> See a service center as soon as possible to inspect/correct wiring. This wiring fault can cause fail-safe audio not to function.
"3D audio left" message heard in left ear only, no audio heard in right ear.	<b>1)</b> Aircraft wired for mono intercom	<b>1)</b> See a service center to wire the installation for stereo headsets.
"3D audio right" message heard in right ear only, no audio heard in left ear	<b>1)</b> Incorrect aircraft wiring (right channel used for mono instead of left, or left/right swapped)	<b>1)</b> See a service center as soon as possible to inspect/correct wiring. This wiring fault can cause fail-safe audio not to function.

### 3D Audio Troubleshooting

## **CLEARANCE RECORDER AND PLAYER**

The GMA 245 contains a digital clearance recorder that records up to 60 seconds of the selected COM radio signal. Recorded COM audio is stored in separate memory blocks. Once 60 seconds of recording time have been reached, the recorder begins recording over the stored memory blocks, starting from the oldest block.

Pressing the **PLAY** Key once plays the latest recorded memory block.

If a COM signal is detected during play of a recorded memory block, play is halted.

Pressing the **PLAY** Key while audio is playing begins playing the previously recorded memory block. Each subsequent press of the **PLAY** Key selects the previously recorded memory block.

Pressing the COM1 MIC or COM2 MIC buttons immediately stops recorder playback.

Powering off the unit automatically clears all recorded blocks.



**Clearance Recorder and Player**

## ENTERTAINMENT INPUTS









The GMA 245 provides four telephone/entertainment inputs:

- Press the **TEL** Key to enable Bluetooth telephone or rear connector wired telephone connection to ICS. When a Bluetooth telephone connection is active the rear telephone connection is disabled. Distribution is controlled by ICS isolation state. When the **TEL** Key is selected, the pilot is always connected to the telephone interface. Other ICS positions are connected to the telephone interface if they hear the Pilot in that ICS state.
- Press the **MUSIC** Key to turn music on/off for all positions. The **SEL** Key selects the music source (Music 1, Music 2, or Bluetooth Music) for all positions. The pilot can choose not to hear music by either turning down the Pilot music volume or enabling **PILOT** 'ICS ISOLATION'. The copilot and passengers can choose not to hear music by turning down the Copilot/Passenger music volume. Refer to the following table on **MUSIC** and **SEL** Key Functions for more information.

## MUSIC EFFECTS

The following music effects are available:



- **Music Equalizer:** Press the **SEL** Key and the **PILOT** Key simultaneously to change the selected Music Equalizer setting. Available settings include: Disabled, Classical, Pop, or Rock.
- **Music Bass Boost:** Press the **SEL** Key and the **CREW** Key simultaneously to change the selected Music Bass Boost setting. Available settings include: Disabled, Medium, or High.

Function	Action	Key Annunciations	
<b>Toggle TEL Audio ON/OFF</b>	Press the <b>TEL</b> Key.		
<b>Receive Bluetooth Phone Call</b>	Incoming call. *		
<b>Answer Bluetooth Phone Call</b>	Press <b>TEL</b> during incoming call (TEL flashing).		
<b>Bluetooth Phone Call Disconnected By Source</b>	Lost connection or user action.	 or 	
<b>Disconnect Bluetooth Phone Call Using GMA 245</b>	Press <b>TEL</b> .	 or 	
<b>Bluetooth Phone Call Initiated by Source/Phone</b>	Press <b>TEL</b> , if TEL is not yet selected.		

\* If **TEL** is selected (green), pre-recorded ringer audio is played.

\*\* If **TEL** is selected (green), no action is required. **TEL** automatically turns blue and connects.

**TEL Key Functions**

Function	Action	Key Annunciations	Notes
Turn <b>MUSIC ON</b>	Press the <b>MUSIC</b> Key (when not selected).		<b>MUSIC</b> in-key annunciator turns green.
Turn <b>MUSIC OFF</b>	Press the <b>MUSIC</b> Key (when selected).		<b>MUSIC</b> in-key annunciator turns OFF (source selection annunciators are unaffected).
Change <b>MUSIC Source</b>	Press the <b>SEL</b> Key.		Music source selection is cyclic, moving from <b>1</b> to <b>2</b> to <b>Bluetooth</b> and then back to <b>1</b> .

MUSIC and **SEL** Key Functions

## BLUETOOTH®

The GMA 245 supports the following Bluetooth profiles and functions:

- A2DP Bluetooth profile for entertainment audio input.
- HFP Bluetooth profile for connection to a telephone (alternate interface for wired TEL function).
- Ability to deliver Bluetooth audio to a VIRB X or VIRB XE Action Camera via HFP 1.6 “Wide Band Speech” format.
- Ability to deliver Bluetooth audio to third-party cameras that are capable receiving audio via the Hands-Free Profile. HFP 1.6 “Wide Band Speech” format is supported by the GMA 245.

During power up the GMA automatically reconnects to the last connected device. This is announced by the Bluetooth annunciator illuminating.

If the same Bluetooth device is used to play music and make a phone call, the phone has priority and the music audio is suspended. Music audio resumes when the phone call disconnects and the music connection is re-established by the source device.

## PAIRING A BLUETOOTH DEVICE

---



**NOTE:** *The Bluetooth annunciator is illuminated only when a Bluetooth device is connected.*

---

Pairing mode allows a new device to discover and create a connection to the GMA 245. Additionally, pairing mode is used to forcefully disconnect a device currently connected to the GMA 245.

Press and hold the **TEL (PAIR)** Key for one second to enter pairing mode. The Bluetooth annunciator flashes to indicate the GMA 245 is in pairing mode and “Pairing Enabled” audio is played. Once the Bluetooth annunciator flashes, the GMA is discoverable for two minutes, or until a device is paired or connected. While discoverable, a Bluetooth enabled device (e.g., cellphone or tablet) can find and pair with the GMA. Refer to the device’s instruction manual for information on how to pair and connect to a new Bluetooth device. Once paired and connected, the Bluetooth annunciator on the GMA stops flashing and remains lit as long as the Bluetooth connection is active. The GMA remembers the last 10 paired devices. When the paired devices list is full and a new device is paired, the least recently connected device is removed from the paired device list.

## PAIRING TO A GARMIN VIRB X OR VIRB XE ACTION CAMERA

---



**NOTE:** *The GMA 245 is capable of connecting to one Bluetooth device at a time.*

---

The GMA 245 supports Bluetooth wireless delivery of pilot headphone audio to versions of the Garmin VIRB action camera that support Bluetooth mic audio input for recording.

Pairing a Garmin VIRB to the GMA 245 works like pairing other Bluetooth audio devices. Once connected, pilot headphone audio will be delivered to the VIRB via Bluetooth. In a connection to the Garmin VIRB, the GMA is the source. Therefore, selecting an entertainment key is not required.

## PAIRING TO A THIRD-PARTY CAMERA

---



**NOTE:** *The third party camera must support receiving audio via the Bluetooth Hands-Free Profile.*

---



**NOTE:** *The third party camera must initiate the initial pairing process with the GMA 245.*

---

Press and hold the **TEL (PAIR)** Key for one second to put the GMA 245 into pairing mode. Reference the third party camera's manual for its pairing instructions. Once the pairing process is complete the GMA 245 and the third party camera will connect to each other via the Hands Free Profile. During this initial connection, Bluetooth Recording Mode will need to be enabled on the GMA 245 for the third party camera. To enable Bluetooth Recording Mode momentarily press the **TEL (PAIR)** and **PILOT** keys simultaneously. When this feature is enabled, the "Bluetooth Recording Mode Enabled" message is played on the intercom. Enabling Bluetooth Recording Mode only needs to be done once. When the GMA 245 and the third party camera connect again in the future Bluetooth Recording Modes will automatically be enabled.



## DISABLING BLUETOOTH

---



To aid in troubleshooting, the GMA 245 Bluetooth can be disabled. To disable, press and hold the **TEL (PAIR)** Key for five seconds. “Bluetooth Disabled” audio is played. To re-enable without powercycling, press and hold the **TEL (PAIR)** Key for five seconds. “Bluetooth Enabled” audio is played.

Note that Bluetooth will always be enabled when the GMA 245 is powercycled.

## BLUETOOTH MEDIA CONTROLS

---

With a Bluetooth device connected, music enabled, and the Bluetooth Music Source selected:

- Press the **NAV2** and **MUSIC** Keys simultaneously to PLAY/PAUSE Bluetooth media.
- Press the **NAV2** and **RADIO MUTE**  Keys simultaneously to skip to the previous Bluetooth media track.
- Press the **NAV2** and **ICS MUTE**  Keys simultaneously to skip to the next Bluetooth media track.

## BLUETOOTH TELEPHONE VOLUME CONTROLS

---

When a Bluetooth telephone call is active and **TEL** is enabled:

- Press and hold the **PILOT** Key to increase the Bluetooth telephone call volume.
- Press and hold the **CREW** Key to decrease the Bluetooth telephone call volume.

## ENTERTAINMENT MUTING

Entertainment muting can be enabled or disabled by the user, however it is always muted during alerts.

### RADIO MUTE

---

Press the **RADIO MUTE**  Key to enable or disable music muting when radio (i.e., COM, NAV, or AUX) audio is active.

### ICS MUTE

---

Press the **ICS MUTE**  Key to enable or disable music muting when intercom audio is active.

## USB POWER JACK

The USB power jack is a dedicated charge port and uses a USB Type A jack. The USB power jack will charge any device while the GMA is powered on. In circumstances where the aircraft power falls below 11 volts, the USB power jack will turn off. When the GMA is turned off, the USB power port is also off. The USB power jack supports a maximum of 2.1 Amps charge current to devices.

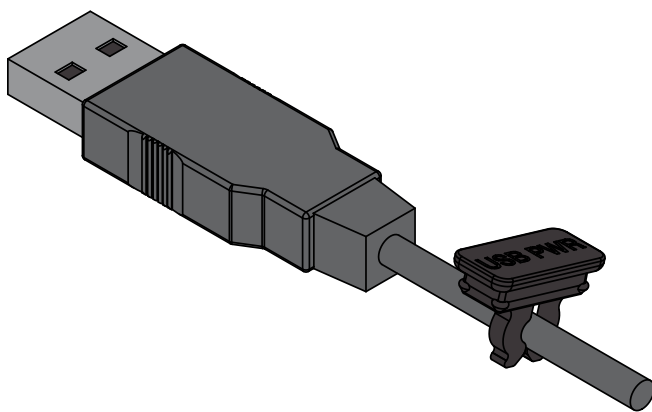





















USB Jack Dust Cover

Note that the GMA USB dust cover can be clipped to any USB cable plugged into the GMA. The dust cover has a clip feature that can attach to a USB cable for temporary storage to prevent losing the cover.

## FAIL-SAFE OPERATION

If there is a failure of the GMA 245 or when power is not applied, a fail-safe circuit connects the pilot's headset and microphone directly to the COM1 transceiver. Audio is not available on the speaker during Fail-safe operation.

Function	Key(s)	Action
Monitor Mute	 or 	Press and hold for 1 second
Radio Mute Intercom		Press and hold for 1 second
3D Audio		Press and hold for 1 second
Split COM	 and 	Press keys simultaneously
Music Equalizer	 and 	Press keys simultaneously
Music Bass Boost	 and 	Press keys simultaneously
Bluetooth Media Play/Pause	 and 	Press keys simultaneously
Bluetooth Media Skip Previous	 and 	Press keys simultaneously
Bluetooth Media Skip Next	 and 	Press keys simultaneously
Bluetooth Call Volume Increase		Press and hold

<p><b>Bluetooth Call Volume Decrease</b></p>		<p>Press and hold</p>
<p><b>Bluetooth Pairing Mode</b></p>		<p>Press and hold for 1 second</p>
<p><b>Bluetooth Recording Mode</b></p>	 and 	<p>Press keys simultaneously</p>

**Alternate Key Function Quick Reference**

Blank Page



Garmin International, Inc.  
1200 East 151st Street  
Olathe, KS 66062, U.S.A.

Garmin AT, Inc.  
2345 Turner Road SE  
Salem, OR 97302, U.S.A.

Garmin (Europe) Ltd  
Liberty House, Bulls Copse Road  
Hounslow Business Park  
Southampton, SO40 9RB, U.K.

Garmin Würzburg GmbH  
Beethovenstrasse 1a  
97080 Würzburg, Germany

Garmin Corporation  
No. 68, Jangshu 2nd Road  
Shijr, Taipei County, Taiwan

[www.garmin.com](http://www.garmin.com)